

TurboDraft™
FIRE EDUCTOR

by Schutte & Koerting

www.turbodraft.net
Operating Instructions

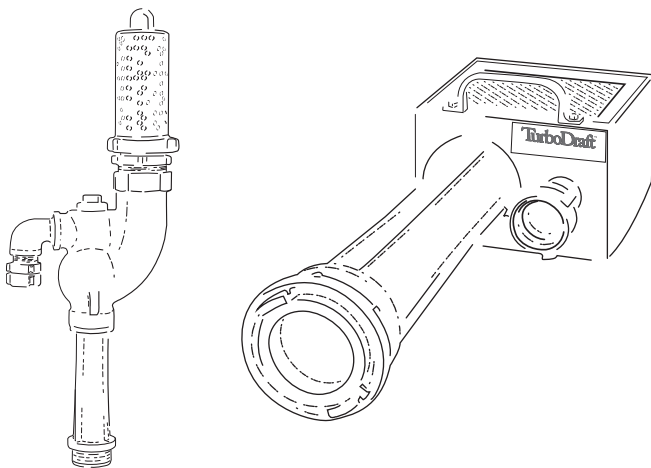

TurboDraft™

Fire Eductor

Operating
Instructions

www.turbodraft.net

Table of Contents

<u>Description</u>	<u>Page</u>
Introduction.....	1
Safety Guidelines.....	2
Care and Maintenance.....	3
TurboDraft Set-Up.....	4 - 6
Tandem TurboDraft Operations.....	7
Strainer Clearing.....	8
Operating Tips.....	9 - 10
Unit Testing.....	11
Using the Distant Water Source Table.....	12
Unit Specifications.....	13
2-1/2" TurboDraft Operating Instructions.....	14
Notes (Intentionally Blank).....	15 - 20

Fire Eductors

For many years Schutte & Koerting has provided portable eductors to the U.S. Navy. These eductors were used for fire fighting onboard ships. The units were used to increase the volume of water available for fire fighting. They utilized the high pressure pumps onboard to supply the motive flow to the eductor which was placed overboard. The design of the unit was for high discharge head and typically had a two-to-one flow ratio. (i.e. 100 gpm of motive, 200 gpm of suction, with total flow of 300 gpm.)

Over the past several years, Schutte & Koerting has worked with several local fire fighters to develop an eductor designed to be used for rural water supply operations. Many of us take for granted that there is a fire hydrant on every corner. Unfortunately, this is not the case. A large percentage of the fire companies outside large cities depend on lakes, ponds, streams, rivers, and even swimming pools as a water source during a fire. Water is currently accessed from these sources in two ways. The first choice is to maneuver the fire truck close (typically 30 feet or less) to the water source and use the onboard pump to draft. This produces the greatest water flow. In many cases, this is not possible due to weather or access restrictions. The second option is to carry a large portable pump to the water source and use this to draft the water and discharge it back to a pumper truck or portable tank close to and accessible to the fire trucks. Portable pumps large enough to supply sufficient water flows tend to be large and require routine maintenance.

Schutte & Koerting has developed an eductor to utilize the third option for water supply. Our eductor utilizes the water stored onboard the fire truck as the motive flow to start the eductor flow and return the motive flow as well as the suction flow back to the fire truck. This allows the fire truck to be at least 150 feet away from the water and still achieve significant net water flow to be utilized for fire fighting.

To put the unit in operation, a 2½ inch hose line and a 5 inch LDH supply line are stretched from the fire truck with the eductor to the water supply. The eductor is placed in the water and the motive line is charged to 150 psig. This immediately starts the flow of water back to the fire truck through the 5 inch LDH supply line. Once the suction flow is established, the first portion of the flow is used to replenish the tank water in the truck. Once the tank has been replenished, the water supply has been established and water can be supplied for use on the fire. The unit was designed for 17.5 feet of head and during our prototype testing we were able to achieve 750 gpm net suction gain. We supplied 200 gpm at 150 psig to the eductor, 750 gpm was developed as a suction flow with a total flow back to the fire truck of 950 gpm. 200 gpm of the 950 gpm was being recycled back to supply the eductor.

Testing was completed in the Spring of 2000 and marketing began in early Autumn of that same year.

Safety Guidelines

1. Carefully read and follow all operating instructions before putting the TurboDraft unit into service.
2. Be sure all pump operators are properly trained in the correct and safe use of the fire pump that is supplying the TurboDraft unit.
3. Proper personal protective equipment should be utilized while operating any fire pump and while present at any emergency scene.
4. Be sure all hose connections are snug and secure.
5. Use caution at all times around any high pressure pump connections.
6. Always understand and follow all department rules, guideline and operating procedures.

Care and Maintenance

The TurboDraft unit is manufactured from aluminum and stainless steel. Little maintenance is required to keep your TurboDraft unit in proper operating condition.

1. Before and after using the TurboDraft, carefully inspect the unit for any damage to the body, tail, and fire connections.
2. After use, flush the unit with clean water to remove any mud, sand or debris from the inside and outside surfaces. Be sure to thoroughly flush the 2½ inch connection, as any sand or grit will effect the swivel action. Also, inspect that the screen is free from any obstructions (grass, leaves, etc.). Mild soap and a soft brush should remove any dried mud or soils from the unit.
3. **IMPORTANT** - Inspect nozzle orifice to be sure there are no obstructions. Any restrictions within the nozzle will dramatically effect the performance of the TurboDraft unit.
4. Safely store the unit securely on or in the apparatus to avoid injury to personnel and damage to the TurboDraft.

TurboDraft Setup/Operation

- The unit requires a 2½ inch discharge line from the fire truck and a 5 inch supply line to return water flow to the fire pump.
- The lines should be stretched from the truck to the water's edge avoiding sharp bends and kinks.
- Before connecting hoses to the TurboDraft, inspect the unit to be sure no debris has entered the inlet or discharge openings.
- Connect the 2½ inch line to a discharge from the pump and to the TurboDraft unit, as shown below.
- Connect a 5 inch LDH supply line to pump intake valve and TurboDraft unit, as shown below.
- Care should be taken to insure all connections are tight and secure. A rope or webbing may be attached to the handle and secured, however, this is not critical because the unit may be retrieved using the hose lines.
- Submerge in 2 to 3 feet of standing water, with the screen/strainer facing up, 1 to 1½ feet of moving water.
- After the above steps are complete the unit is ready to be put into operation.



TurboDraft Set-Up/Operation

- Engine should be placed into pump gear and truck prepared for pumping operations.
- The intake valve should be closed.
- Open the bleeder on the suction intake valve to allow any air in the hose to be vented.
- Open the tank-to-pump valve.
- Increase the engine pressure to 175 PSIG.
- Open the 2½ inch discharge supplying the TurboDraft unit and maintain discharge pressure at 175 PSIG. This is required to start suction flow back to the truck.
- As the 2½ inch line is charged, the 5 inch line will immediately start to fill.
- Close the bleeder once water reaches it and slowly open the suction intake valve.
- The water supply is now established.



TurboDraft Set-Up/Operation

- Close the tank-to-pump valve.
- At this point the truck's tank should be refilled. Open the tank fill valve $\frac{1}{4}$ to $\frac{1}{2}$ open and allow tank to fill. The truck tank should always be kept full to allow the water supply to be re-established, if necessary.
- With 100 ft. of 5 inch hose, it should take approximately 100-250 gallons of water to establish a water supply to the truck.
- Once tank is full, close tank fill valve.
- Slowly open required discharge valve(s).
- Maintain the required pressure (see Chart 1, page 12) on the TurboDraft $2\frac{1}{2}$ inch line at all times.
- During the use of the TurboDraft unit, care should be taken not to exceed supply source availability. This will cause the supply line from unit to collapse. (see Flow Chart 1 on page 12).
- Supply line (5 inch LDH) from the unit should always be monitored. Maximum flow from the TurboDraft unit is achieved when the supply line starts to become soft.
- If the supply line flow is exceeded and the line collapses, simply open the tank-to-pump valve and decrease the discharge flow until the supply line recovers. Once stabilized, close the tank-to-pump valve and top off the tank as soon as possible.

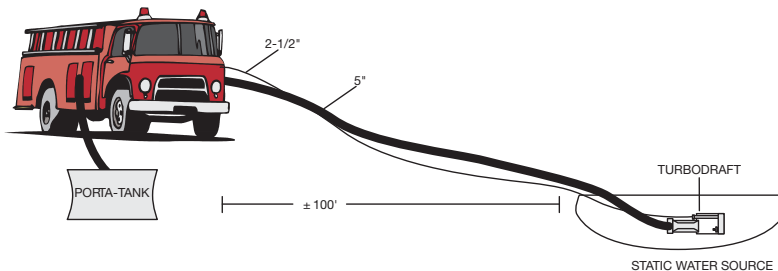

Tandem TurboDraft Operations

* Minimum required pump size: 500 GPM

Set up Operation:

- Set up and establish the first TurboDraft unit as discussed under “TurboDraft Set-Up/Operation” on pages 4-6. Refill the tank.*
- Lay out the second unit connecting its 2½ inch charge line to a 2½ inch outlet and its 5 inch supply line to the truck’s officer side steamer connection.**
- Using the first TurboDraft as a supply, charge the second unit’s 2½ inch supply line.
- Once the second unit’s 5 inch line has been bled free of air, slowly open its suction valve.
- Begin water supply operations by slowly opening the required discharge valves.

* The unit with the longest 5 inch line should be set up first and connected to the driver side steamer/intake.

** The second steamer must be fitted with a suction valve and air bleeder. A front or rear suction may be used in lieu of the other steamer if a suction of hard sleeve is installed between the 5 inch hose and the suction connection. This is necessary to prevent premature collapse of this line.

Strainer Clearing

During operation of the unit it may become necessary to clear the strainer of grass or debris from the water source. This is easily performed and should only take 15 to 30 seconds.

- Discontinue water supply operations by closing down all discharges from the truck except for the line supplying the TurboDraft unit.
- Open the tank-to-pump valve.
- Slowly close the suction intake valve. This will cause the flow of water to backup into the strainer and clear any obstructions from the screen.
- Keep valve closed for 15 to 30 seconds to ensure the debris is cleared from the strainer area.
- Slowly open the suction intake valve to re-establish the water supply.
- Close tank-to-pump valve and open tank fill valve $\frac{1}{4}$ to $\frac{1}{2}$ and refill tank.
- When tank is full, close tank fill valve and resume flow operations.

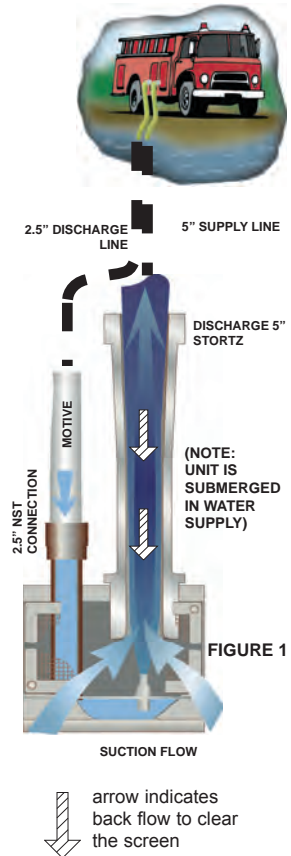

Operating Tips

- Maintain pump seals per manufacturer's recommendations and tightly close all valves and bleeders to prevent air leaks and loss of prime.
- Take care to keep discharge flow rates within TurboDraft's rated capacity (see Chart 1 on page 12). If you do not, the suction hose will collapse.

NOTE Keep hose lays and lifts as short as possible.
The shorter the hose and lift, the greater your flow.

- The supply line (or longest supply line if two units are being used) should be connected to the driver side pump panel. This allows the driver to feel and see the hose. The TurboDraft's maximum flow is achieved when the supply hose starts to become soft.
- If the supply hose does collapse, quickly open the tank-to-pump valve to reestablish flow. Then, reduce discharge flow to within units' capability and top off tank.

NOTE When operating near capacity or under fluctuating discharge conditions, be ready by keeping your hand on the tank-to-pump valve.

- If the TurboDraft cannot be adequately submerged, use tennis balls (or other floating object) or a booster line sprayed above its inlet to break the vortex and prevent air from getting into the pump (i.e., loss of prime).

Operating Tips

- Under heavy algae surface debris conditions, back flushing (shown on page 8) may not be sufficient to prevent clogging of the strainer. Use a booster or forestry line to keep as much algae away as possible.
- If you have a pressure governor, use it. This will help maintain the constant discharge pressure required to the unit.
- TurboDraft use should be regularly practiced and results confirmed individually as this may vary slightly between trucks and operators.
- The pump's rated capacity at 150 psi should exceed the expected flow rate (see Chart 1 on page 12) by 300 GPM. The TurboDraft unit cannot achieve maximum rated flows with pumpers having rated capacities of less than 1,000 GPM.

Unit Testing

- A simple test can be performed to determine the fire flow of a given water source.
- In addition to the TurboDraft setup, connect a master stream device with a straight bore nozzle.
- See page 12 to determine the estimated fire flow for your location and required nozzle bore for deck gun.
- Place the TurboDraft unit in operation as shown on pages 4 through 6.
- Once the water supply is established, start flowing water to the deck gun and continue to increase water flow to the deck gun until the 5 inch line from the TurboDraft starts to get soft. At this point you have reached the maximum flow.
- Read the pressure at the deck gun. Refer to Chart 3 below to determine the flow for the deck gun at that pressure.



Chart 3

GPM At Various Pressures (PSIG)																			
Nozz. Dia.	30	35	40	45	50	55	60	66	70	76	80	85	90	95	100	105	110	115	120
1½"	206	222	238	252	266	279	291	305	315	328	336	347	357	366	376	385	394	403	412
1⅝"	308	332	355	377	397	417	435	456	470	490	502	518	533	547	562	575	589	602	615
1⅞"	366	395	423	448	473	496	518	543	559	583	598	616	634	651	668	685	701	717	732

Using The Distant Water Source Table

Chart 1

Length of 5" Hose	Lift	Pump Discharge Pressure	Max. Avail. Fire Flow
50'	10'	175 psig	670 GPM
	20'	175 psig	470 GPM
100'	10'	180 psig	570 GPM
	20'	180 psig	400 GPM
150'	10'	185 psig	480 GPM
	20'	185 psig	325 GPM
200'	10'	190 psig	440 GPM
	20'	190 psig	280 GPM

1. Determine the required hose length (use the longer of the two if two TurboDraft units will be used). Refer to Chart 2 below for friction loss in hose line.
2. Estimate or measure the required lift. This is best done by pre-planning water source and actual measurement is preferred, as lifts can be visually deceiving.

Hint: Place a pressure gauge on the end of a hose line. Place the gauge at water's edge and the opposite end of hose at truck elevation. Fill hose with water leaving the truck end open to atmosphere. The lift can be estimated by multiplying the pressure gauge reading (psi) by 2.3.

3. Read across and determine the required discharge pressure for the TurboDraft's 2½ inch line and the maximum available fire flow.

Chart 2

Friction Loss / 100 Ft. Of 5" Hose								
GPM	400	500	600	700	800	900	1000	1200
PSI	1.1	1.7	2.4	3.3	4.2	5.3	6.5	9.3

Specifications

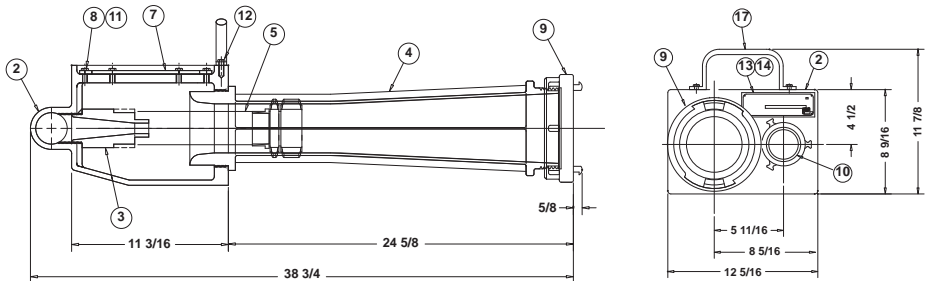

MK NO	DESCRIPTION	QTY	MATERIAL	REMARKS
01	FIRE EDUCTOR ASSY.	1	ALUMINUM	
02	BODY	1	ALUMINUM	99E0123J002
03	NOZZLE	1	ALUMINUM	0010113J001
04	TAIL	1	ALUMINUM	98GB137J002
05	INLET PIPE	1	ALUMINUM	0010166J001
06	FILTER SCREEN	1	SST TY 304	0010115J001
07	BOLTING PLATE	2	ALUMINUM	0010240J001
08	HEX HEAD CAP SCREW	8	18-8 SST	AAA24D22132
09	5" FIRE HOSE ADAPTER	1	ALUMINUM	001B201J001
10	2-1/2" FIRE HOSE ADAPTER	1	ALUMINUM	98S0360J001
11	KEENSERT INSERT	8	SST TY 303	0010124J001
12	HEX HEAD CAP SCREW	2	18-8 SST	AAA26D22132
13	NAME PLATE	1	ALUMINUM	0010196J001
14	DRIVE SCREWS	4	0 - 1/8, 18-8 SST	0010197J001
15	I.O. & M. MANUAL	1	ALUMINUM	0010244J001
16	11-1/2" BOLT PLATE	2	ALUMINUM	0010240J002
17	HANDLE	1	SST A351 CF8M	0110195J001

Distant Water Source Situation ^{1,2,3}			
Length of 5" Hose	Lift	Pump Discharge Pressure	Max. Avail. Fire Flow ^{1,2}
50'	10'	175 psig	670 GPM
	20'	175 psig	470 GPM
100'	10'	180 psig	570 GPM
	20'	180 psig	400 GPM
150'	10'	185 psig	480 GPM
	20'	185 psig	325 GPM
200'	10'	190 psig	440 GPM
	20'	190 psig	280 GPM

Note: Using 6" supply line can increase unit output by decreasing line friction losses.

¹ Theoretical, based on test curves of 9/21/99 and hose friction loss per NFPA® Fire Protection Handbook, 15th Edition, Table 17-7H, actual friction losses may vary depending upon hose and coupling design/manufacturer.

² All flows achievable with 1,000 GPM rated pumper based on NFPA recommended pump curves. Use larger pumper where maintenance/performance is questionable.

³ Minimum available flow from water source recognized by ISO for grading purposes is 250 GPM. ISO does not recognize drafting sources requiring a lift in excess of 18' (This is not a drafting device as it operates under pressure.)

Net weight of unit: 52 lbs.

2-1/2" TurboDraft – Operating Instructions

TurboDraft Operation

Once the TurboDraft Fire Eductor has been set up it can be quickly placed into service. The steamer suction valve is left closed and its air bleeder is opened. The 1½ inch line is charged to approximately 175 psig. The force of the flow combined with TurboDraft eductor technology creates a suction which draws water from the standing water supply. As this happens, the return line is charged back to the fire truck. Once the air is bled from the supply line, the bleeder is closed and the steamer valve is opened. At this point the water supply has been established. 60 GPM is re-circulated through the truck to maintain a continuous flow and 264 GPM is available to supply tanker trucks or fill portable tanks. Useable fire flow will vary based on elevation and hose friction loss. (See table below.)



Tap Water Sources in Remote Locations

Rural fire companies need creative solutions to utilize water sources that are not accessible using typical drafting techniques. Schutte & Koerting's TurboDraft Fire Eductor allows fire companies to tap into water supplies like ponds, streams, and swimming pools up to 250' away and can generate flows up to 264 GPM.

Overall Length: 30"
 Weight: 20 lbs.
 Connections: 1½" NST Female Inlet
 2½" NST Male Outlet

2 1/2" TurboDraft Fire Eductor Performance

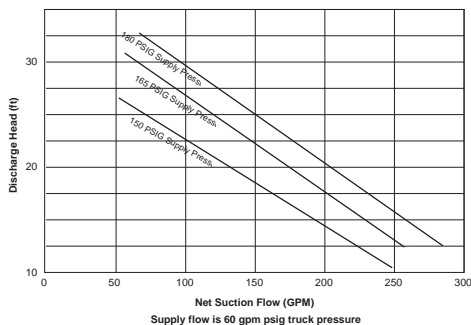

Distant Water Source Situation for 2½" Unit

Length of 2½" Hose	Lift	Pump Discharge Pressure	Max. Avail. Fire Flow
50'	10'	175 psig	264 GPM
	20'	175 psig	185 GPM
100'	10'	180 psig	224 GPM
	20'	180 psig	157 GPM
150'	10'	185 psig	189 GPM
	20'	185 psig	128 GPM
200'	10'	190 psig	173 GPM
	20'	190 psig	110 GPM

Notes

Notes

Notes

Notes

Notes

Notes

