

TurboDraft™

F I R E E D U C T O R

- Lightweight design sets up in minutes with minimal personnel using 5-inch large diameter hose (LDH)
- No need for cumbersome hard suction hose
- Gain access to static water sources previously unreachable using traditional drafting techniques
- Usable in lakes, ponds, streams, rivers, canals, swimming pools, etc.
- Generate usable fire flow rates of 670 gpm or more
- Recognized by insurance agencies as an alternate water supply source
- Eliminate need for multiple dry hydrant installations
- No permits, engineering or maintenance
- Suitable for emergency dewatering and flood mitigation



NO HYDRANT—NO PROBLEM

TurboDraft™

WATER EDUCTOR FOR FIRE FIGHTING

TAP WATER SOURCES IN REMOTE LOCATIONS

Rural fire departments need creative solutions to use water sources that are not accessible using typical drafting techniques. Schutte & Koerting's TurboDraft Fire Eductor allows fire departments to tap into water supplies like lakes, ponds, streams, and rivers, etc. at a distance of up to 200' or more. Usable fire flows of 670 gpm or more may be achieved dependent upon hose layout and elevation change.

TURBODRAFT SETUP

Weighing only 48 lbs., the 5-inch TurboDraft Fire Eductor can easily be put into service with minimal personnel. Setup is quick and simple utilizing standard fire service hose lines. Once the 2½" feed line and 5" LDH return line are connected, the TurboDraft is deployed into the static source. (See Figure 1)

TURBODRAFT OPERATION

Once the TurboDraft Fire Eductor has been deployed it can be quickly placed into service. The inlet suction valve of the pumping engine is left closed and its air bleeder is opened. The 2½" line is charged using water from the onboard water tank. The force of this flow combined with TurboDraft eductor technology creates a suction that draws water from the static source. As this happens, the large diameter hose (LDH) is charged back to the pump suction valve. After the air is bled from the LDH, the bleeder valve is closed and the intake valve is opened. At this point the water supply has been established. 200 gpm is re-circulated through the pump to maintain a continuous flow without the need of the onboard water tank. The balance of the "drafted" water is now available to supply hand lines, hose lays, or to fill tanker/tender operations. Usable flows will vary based on elevation and hose friction loss. (See Table 1)

Figure 1



Table 1

| Distant Water Source Situation ^{1,2,3} for 5" Unit | | | |
|---|------|-------------------------|------------------------------------|
| Length of 5" Hose | Lift | Pump Discharge Pressure | Available Fire Flow ^{1,2} |
| 50' | 10' | 165 psig | 670 GPM |
| | 20' | 165 psig | 470 GPM |
| 100' | 10' | 170 psig | 570 GPM |
| | 20' | 170 psig | 400 GPM |
| 150' | 10' | 175 psig | 480 GPM |
| | 20' | 175 psig | 325 GPM |
| 200' | 10' | 180 psig | 440 GPM |
| | 20' | 180 psig | 280 GPM |

Values listed reflect the minimum available flow rate in gallons per minute. NOTE: Using 6" large diameter hose line can increase usable flow by decreasing line friction loss.

^{1,2,3} See back cover for details.

FIRE FIGHTING APPLICATION CHALLENGES

1. Access to a water source is more than 30 feet and typical drafting techniques cannot be implemented

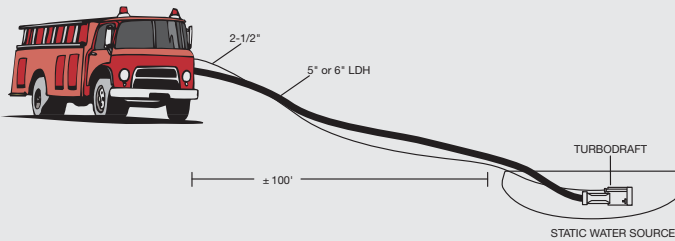

Solution A

By stretching a 2½" supply line and a 5" or 6" return line, usable water supply of 600 GPM or more can be achieved at a distance of over 100 feet. Actual usable water supply will be determined by discharge line loss and elevation differences between water source and pump suction.

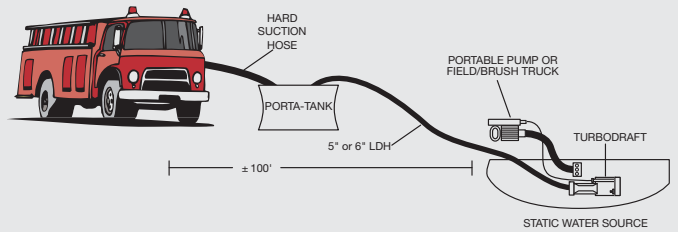

Solution B

Utilize a portable pump or truck mount pump (minimum rating of 200 gpm @ 150 psi) to supply the TurboDraft Fire Eductor. Achieve usable fire flows of 800 GPM or more.

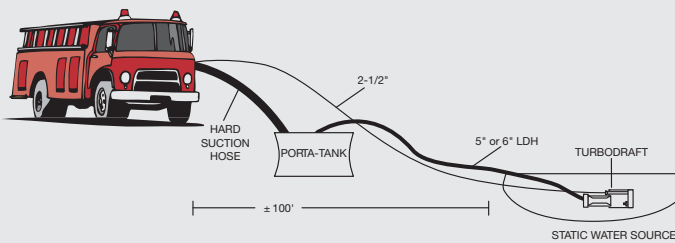

Solution C

One or more TurboDraft units operating to fill a portable tank allowing pumper to have access with hard suction hose. TurboDraft lines are directed into tank while pumper drafts to supply the units as well as the fire ground or to fill tankers.

2. Due to congestion at the fire scene, portable tanks for tanker delivery need to be set up at remote location

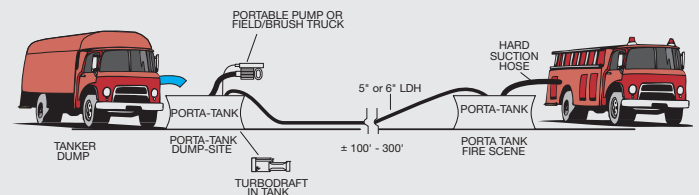

TurboDraft can be used in conjunction with a portable pump to provide constant flow between remote tanks and fire scene supply tank. Flow from the remote tanks can be controlled by a gate valve in the 5" or 6" supply line. If discharge line is blocked, supply line flow is discharged into portable tank and recycled.

3. Flood mitigation and water transfer

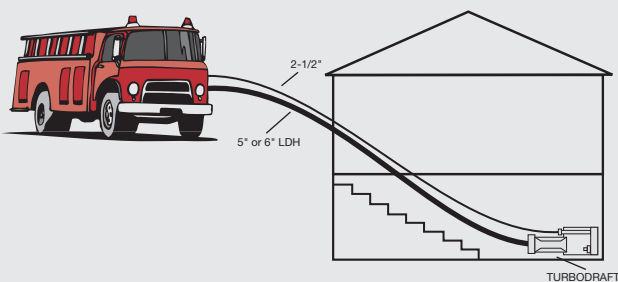

TurboDraft can also be employed in emergency flood situations. TurboDraft's ability to transfer large volumes of water in a short amount of time makes it a critical piece of equipment for dewatering basements and other low-lying areas where water collects.

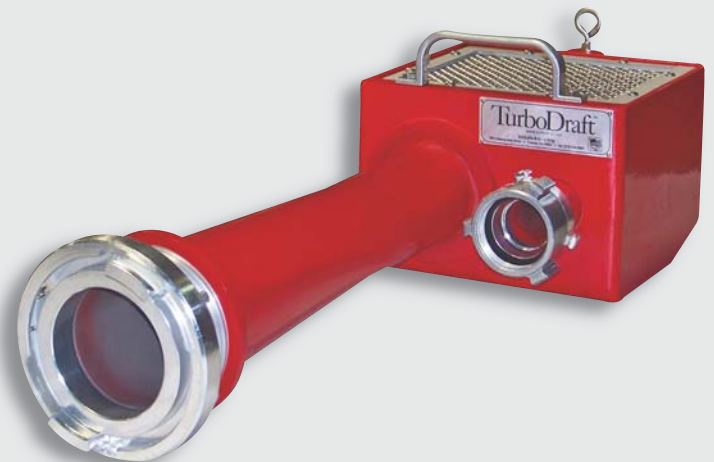

Homeland Security-Municipal Emergencies

Although the TurboDraft was designed with the rural fire department in mind, large municipal departments can also utilize the TurboDraft eductor technology. The majority of city-based departments are generally not equipped for non-hydrant water supply operations. During natural or man-made emergencies municipal water supply systems can be rendered useless. The TurboDraft allows departments with basic hose lines and minimal training to access static sources for fire suppression as well as flood mitigation operations.



TurboDraft™

WATER EDUCTOR FOR FIRE FIGHTING PROVEN TECHNOLOGY

Schutte & Koerting eductors have been used in thousands of industrial applications for more than a century. They employ the venturi principle to create flow and increase pressure. Eductors use the kinetic energy of one liquid to create motion in a second liquid. With no moving parts to break, eductors are one of the most reliable technologies ever invented.

S&K water eductors for fire fighting have been standard equipment on many U.S. Navy ships since WWII. The same eductor technology has also been used in fire fighting for more than thirty years in foam eductor systems.



2510 Metropolitan Drive
Trevose, PA 19053
tel: (215) 639-0900
fax: (215) 639-1597
email: turbodraft@s-k.com

TurboDraft Performance for 5" Unit

Graph 1

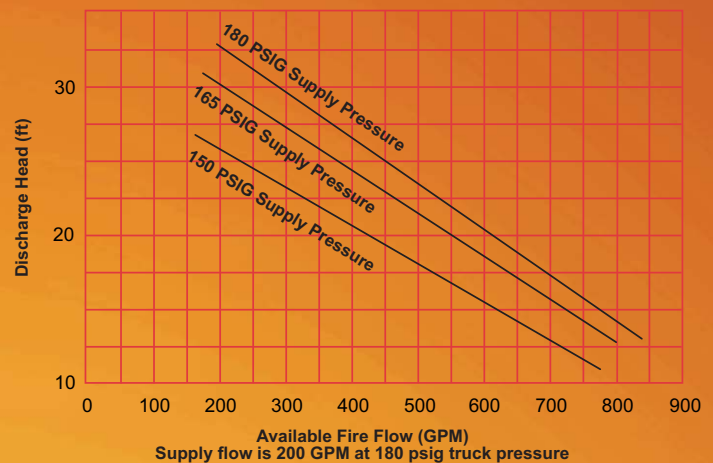

¹ Theoretical, based on test curves of 9/21/99 and hose friction loss per NFPA® Fire Protection Handbook, 15th Edition, Table 17-7H, actual friction losses may vary depending upon hose and coupling design/manufacture.

² All flows achievable with 1,000 GPM rated pumper based on NFPA recommended pump curves. Use larger pumper where maintenance/performance is questionable.

³ Minimum available flow from a water source recognized by ISO for grading purposes is 250 GPM. ISO does not recognize drafting sources requiring a lift in excess of 18' (This is not a drafting device as it operates under pressure.)

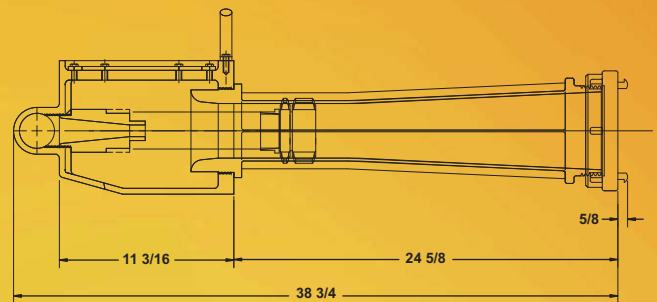

For more information, please visit our website
or call us to speak with a representative

www.turbodraft.net